

Dimensions Class 300 • Bolted Cover

Figure 2370

Check Valve, Threaded Ends

Figure 2374

Check Valve, Socket Weld Ends

Size Range:

½ through 2 inches

Design Features:

- Integral Seat
- Recessed Retained Gasket
- MSS SP-42
- ASME B16.34

Dimensions and Weights

Valve Size	Weight (lbs)	Dimensions (inches)	
		A	B
½	4.2	3.23	3.3
¾	4.2	3.23	3.3
1	5.8	4.13	3.4
1½	10.1	4.92	3.9
2	13.1	5.31	4.1

Please refer to page 28 for Pressure-Temperature Ratings.

Industry Standards

Pipe Threads	ASME B1.20.1
Wall Section	ASME B16.34
Socket Weld Ends	ASME B16.11
End-to-End	Manufacturer's Standard
Pressure Temp. Ratings	ASME B16.34
Testing	API 598

Materials of Construction

1	Body	ASTM A351 CF3M
2	Cover	ASTM A351 CF8M
3	Disc	ASTM A351 CF8M
4	Hinge Arm	ASTM A351 CF8M
5	Hinge Pin	ASTM A276 T316
6	Disc Washer	ASTM A276 T316
7	Disc Nut	ASTM A194 GR 8M
8	Gasket	PTFE
9	Cover Bolt	ASTM A193 GR B8
10	Cover Bolt Nut	ASTM A194 GR 8
11	ID Tag	ASTM A276 T304

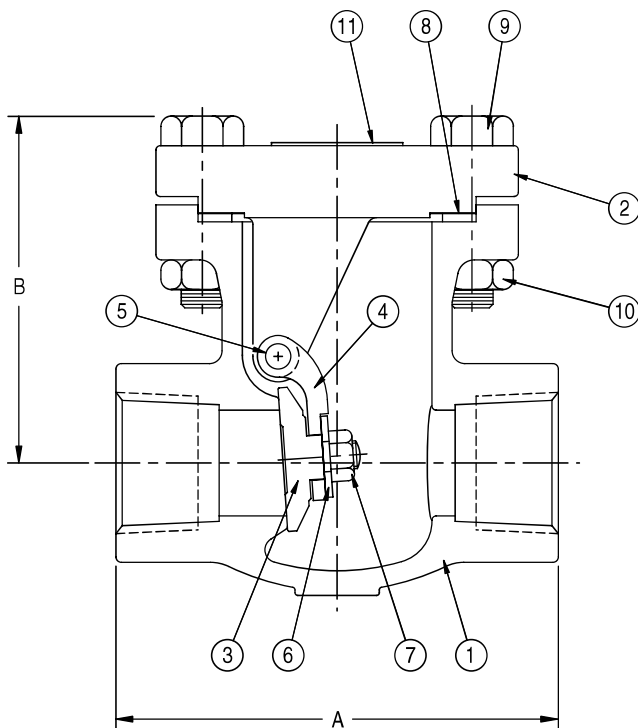

Fig. 2370