

Dimensions Class 150 • OS&Y • Solid or Flexible Wedge Disc

Figure 117

Gate Valve, Raised Face, Flanged Ends,
Solid Wedge Disc (½ - 1")
Flexible Wedge Disc (1½ - 24")

Size Range:

½ through 24 inches

Design Features:

- Bolted Bonnet
- Rising Stem
- Integral Seat
- MSS SP-42
- API 603
- ASME B16.34

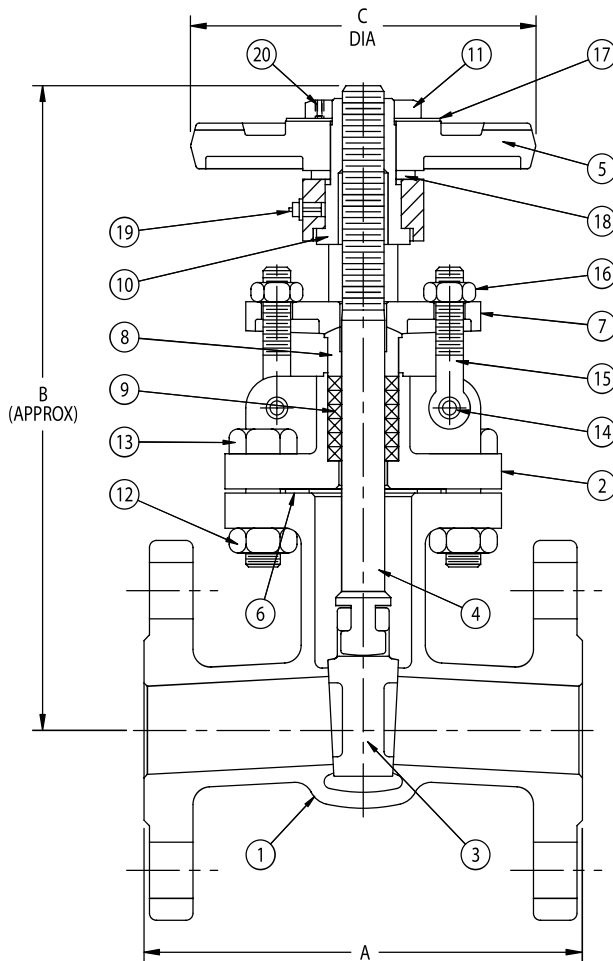

Fig. 117

Dimensions and Weights

Valve Size	Weight (lbs)	Dimensions (inches)		
		A	B (open)	C
½	7.4	4.25	8.1	3.9
¾	8.3	4.63	8.5	3.9
1	10.0	5.00	9.1	3.9
1½	18.0	6.50	11.0	5.5
2	27.0	7.00	12.6	6.3
2½	37.5	7.50	15.1	7.9
3	46.3	8.00	16.7	7.9
4	75.0	9.00	20.9	8.8
6	128.0	10.50	28.7	11
8	216.1	11.50	36.9	11.8
10	291.1	13.00	43.9	13.8
12	436.6	14.00	51.9	17.7
14	703.4	15.00	58.5	17.7
16	1018.7	16.00	66.9	19.7
18	1190.7	17.00	74.8	22.0
20	1631.7	18.00	82.5	28.0
24	2434.3	20.00	97.4	31.5

Please refer to page 28 for Pressure-Temperature Ratings.

Industry Standards

End Flanges	ASME B16.5
Wall Section	ASME B16.34
Face-to-Face	ASME B16.10
Pressure-Temp Ratings	ASME B16.34
Design	API 603
Testing	API 598

Materials of Construction

1	Body	ASTM A351 CF8M
2	Bonnet	ASTM A351 CF8M
3	Disc	ASTM A351 CF8M
4	Stem	ASTM A276 T316
5	Handwheel	ASTM A536
6	Gasket	PTFE
7	Gland Flange	ASTM A351 CF8
8	Gland	ASTM A276 T316
9	Packing	PTFE
10	Stem Nut	ASTM A439, D2
11	Handwheel Nut	ASTM A276 T304
12	Bonnet Bolt Nut	ASTM A194 GR 8
13	Bonnet Bolt	ASTM A193 GR B8
14	Eyebolt Pin	ASTM A276 T304
15	Eyebolt	ASTM A193 GR B8
16	Eyebolt Nut	ASTM A194 GR 8
17	ID Tag	304 SS
18	Washer	ASTM A536
19	Grease Fitting	Nickel-plated Copper
20	Set Screw	Steel