

spirax sarco

Iron Liquid Drain Traps FA-30, FA-75, FA-150

The float-operated liquid drain trap discharges continuously in direct response to variations in liquid flow rate, assuring thorough drainage of the system.

Model	FA-30	FA-75	FA-150
Sizes	3/4", 1", 1-1/2", 2"		
Connections	NPT		
Construction	Cast Iron Body, Stainless Steel Internals		

Typical Applications

Receiver and air line drainage, draining a liquid from its vapor phase

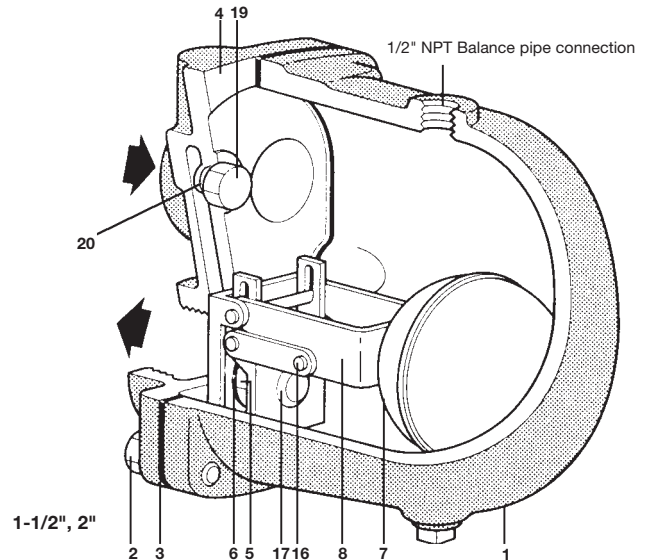
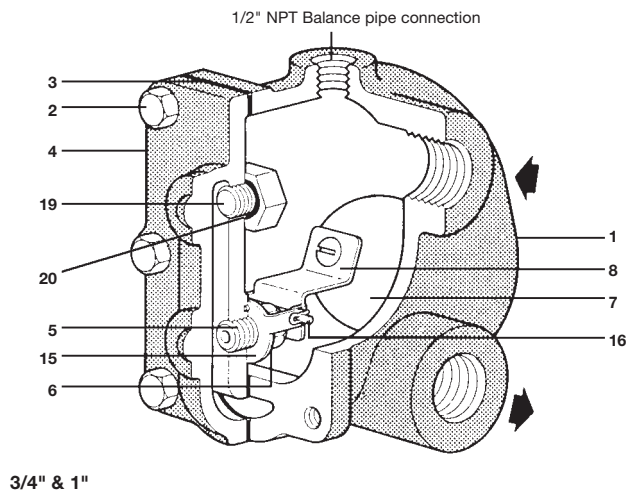

Limiting Operating Conditions

Max. Operating Pressure (PMO)

Up to 150 psig. The PMO depends on the model selected and the specific gravity of the liquid being drained. See TIS 7.318.

Max. Operating Temperature FA-30, 75 450°F (232°C)
FA-150 200°F (93°C)

Pressure Shell Design Conditions

PMA FA-30,75: 125 psig/0-450°F 9 barg/0-232°C
Max. allowable pressure FA-150: 150 psig/0-200°F 10 barg/0-93°C

TMA FA-30,75: 450°F/0-125 psig 232°C/0-9 barg
Max. allowable temperature FA-150: 200°F/0-150 psig 93°C/0-10 barg

Construction Materials

No.	Part	Material	
1	Body	Cast Iron	ASTM A126 CL B
2	Cover Screws	Steel	ASTM A449
3	Cover Gasket	Graphite	
4	Cover	Cast Iron	ASTM A126 CL B
5	Valve Seat	Stainless Steel	AISI 420F
6	Valve Seat Gasket	Stainless Steel	AISI 302
7	Float	Stainless Steel	AISI 304
8	Lever	Stainless Steel	AISI 301/304
15	Seat Bracket	Stainless Steel	AISI 301/304
16	Pivot Pin	Stainless Steel	AISI 302/303
17	Valve Head & Bracket Assy	Stainless Steel	AISI 300/440
19	Plug	Brass	ASTM B16
20	Plug Gasket	Stainless Steel	ASTM A240

Local regulation may restrict the use of this product below the conditions quoted. Limiting conditions refer to standard connections only.
In the interests of development and improvement of the product, we reserve the right to change the specification.

TI-7-306-US 4.15

Iron Liquid Drain Traps

FA-30, FA-75, FA-150

Capacity

The discharge capacity depends on the differential pressure (inlet pressure minus outlet pressure) and the specific gravity of the liquid being drained. See TIS 7.318.

Sample Specification

The liquid drain trap shall be of the float type with screwed NPT connections. Valve mechanism and float shall be stainless steel with hardened working surfaces, designed to retain a water seal at all times. A 1/2" NPT tapping shall be provided for a balance pipe. All internals are to be renewable and field serviceable.

Installation

The trap must be fitted in a horizontal pipe line with direction of flow as indicated and so that the float mechanism is free to rise and fall in a vertical plane. Full-flow isolating valves should be placed to permit servicing. The high point of the body is provided with a 1/2" NPT tapping for a balance pipe, which is essential for satisfactory operation of this unit. The balance pipe must be connected with a continuous rise between the tapping provided on the body of the trap and the vessel being drained. The trap discharge should be piped to a safe place.

Maintenance

This product can be maintained without disturbing the piping connections. Complete isolation of the trap from both supply and return line is required before any servicing is performed.

The trap should be disassembled periodically for inspection and cleaning of the valve head and seat.

Worn or damaged parts should be replaced using a complete repair kit.

Complete installation and maintenance instructions are given in IMI 7.306 which accompanies the product.

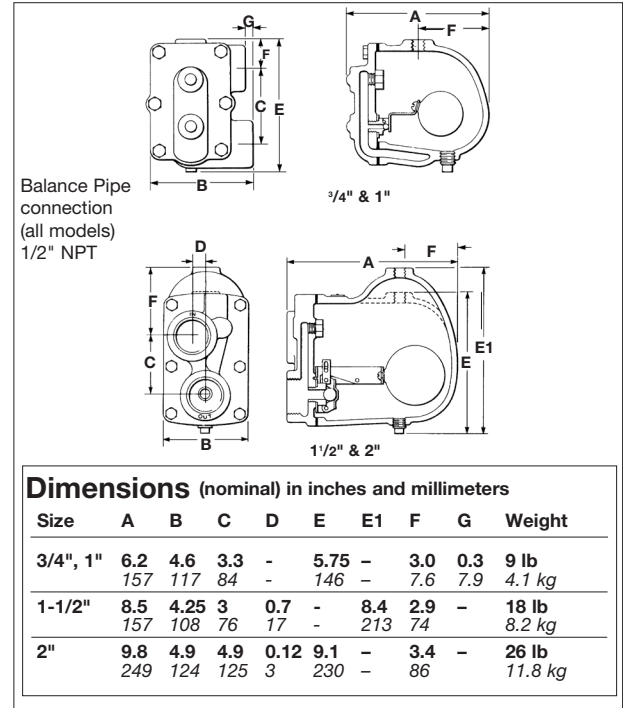

Liquid drain traps can be used to drain most liquids from most gases. However, some applications, particularly those involving hazardous or unusual fluids, may be subject to regulation or may otherwise require special consideration.

Spirax Sarco will endeavor to provide whatever data is necessary to assist in product selection.

Spare Parts

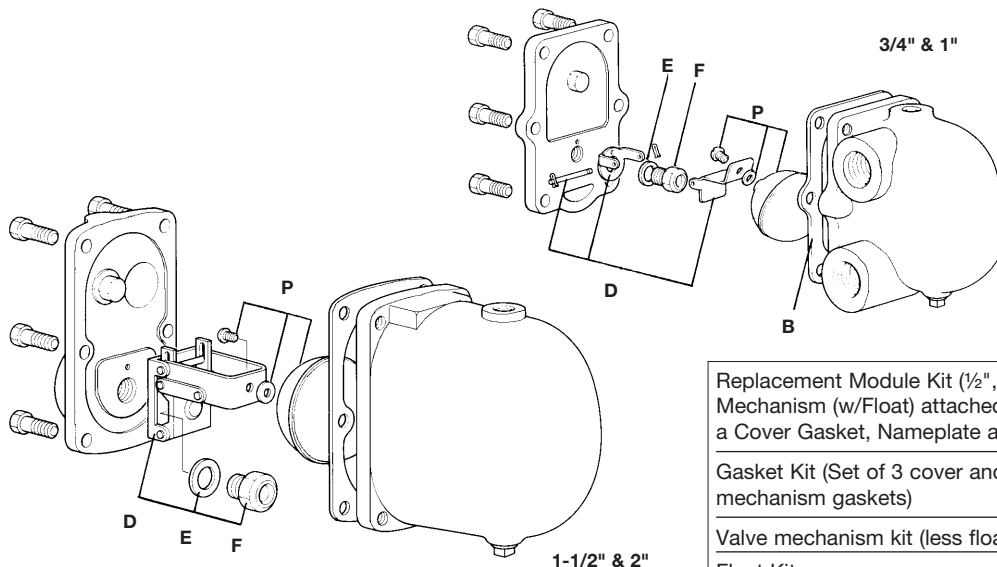

Replacement Module Kit (1/2", 3/4", 1" only)- Consists of: Valve Mechanism (w/Float) attached to a Cover and supplied with a Cover Gasket, Nameplate and a set of Cover Bolts.

Gasket Kit (Set of 3 cover and mechanism gaskets) B, E

Valve mechanism kit (less float) D, E, F

Float Kit P

TI-7-306-US 4.15