



BTS7

Balanced Pressure Thermostatic Steam Trap

Description

The Spirax Sarco BTS7 is a sealed thermostatic steam trap designed to remove condensate from clean (chemical free) steam systems with minimal condensate retention. Applications include steam barriers, block and bleed installations, mains drainage and CIP/SIP of vessels and reactors and process lines.

Manufactured in 316L stainless steel with minimal crevices, it is self-draining and operates close to steam temperature. Each trap is individually packaged within an "ISO CLASS 7" clean environment with protective end caps and sealed in a protective plastic bag.

Options

Fixed bleed to ensure 'Fail Open' operation. Special connections to suit most piping systems.

Standards

- The BTS7 has been designed and manufactured in general accordance with ASME BPE standards.
- The unit also complies with the requirements of the EU Pressure Equipment Directive/UK Pressure Equipment (Safety) Regulations.

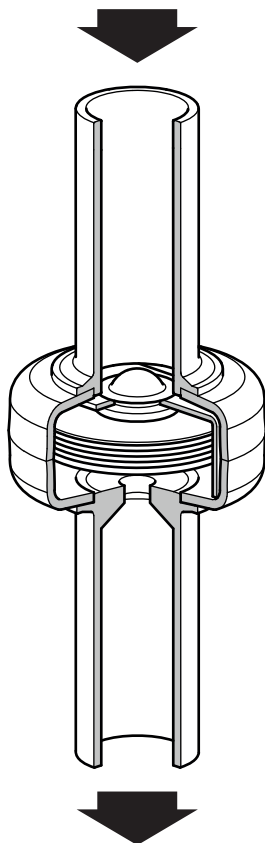

BTS7
Tube ended variant

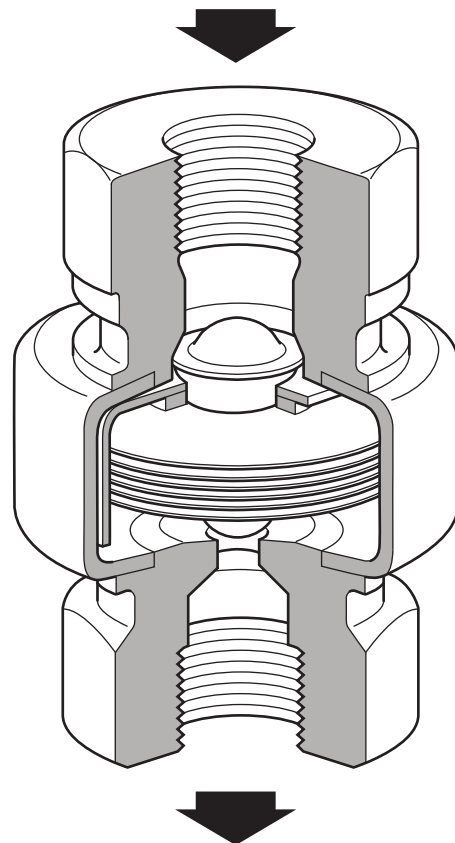

BTS7
Screwed ended variant

Certification

This product is available with the following certification:

- Certificate of Compliance for FDA and ADI Free Statement - F.O.C
- TSE-BSE Statement - F.O.C.
- Declaration of Conformity BS EN ISO 14644-1:2015 Class 7 Clean Room - F.O.C.
- Typical Test Report - F.O.C.

Note: All certification/inspection requirements must be stated at the time of order placement, and may be subject to additional cost as detailed above.

Sizes and pipe connections

Tube Ended Variants	Standard	Issue	Type	Sizes				
	Imperial O/D		16swg wall			½"	¾"	1"
	DIN 11850		Series 1		DN10	DN15		
	ISO 1127		Series 1	DN8	DN10	DN15		

Screwed Ended Variants	Standard	Issue	Type	Sizes				
	BSP				¼"	½"	¾"	1"
	NPT				¼"	½"	¾"	1"

Pressure/temperature limits

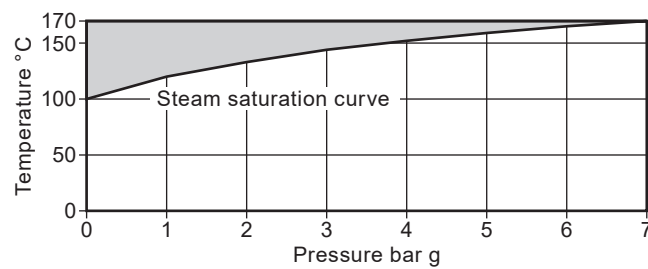

The product should not be used in this region as damage to the internals may occur.

Body design conditions	PN7
PMA Maximum allowable pressure	7 bar g @ 170 °C
TMA Maximum allowable temperature	170 °C @ 7 bar g
Minimum allowable temperature	-254 °C
PMO Maximum operating pressure for saturated steam service	7 bar g @ 170 °C
TMO Maximum operating temperature	170 °C @ 7 bar g
Minimum operating temperature	0 °C
Designed for a maximum cold hydraulic test pressure of:	10.5 bar g

Materials

No.	Part	Material	
1	Body	Stainless steel	316L (1.4404)
2	Capsule element	Stainless steel	316L (1.4404)

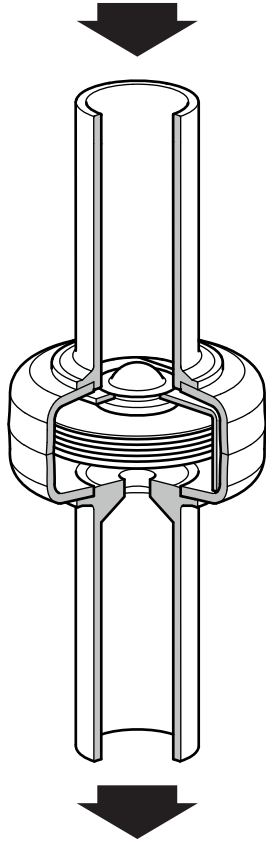

BTS7
Tube ended variant

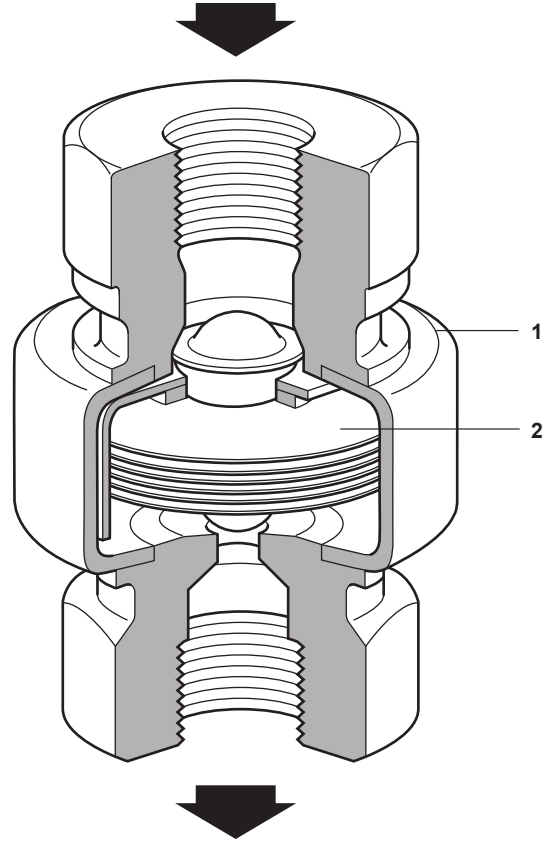

BTS7
Screwed ended variant

Capacities

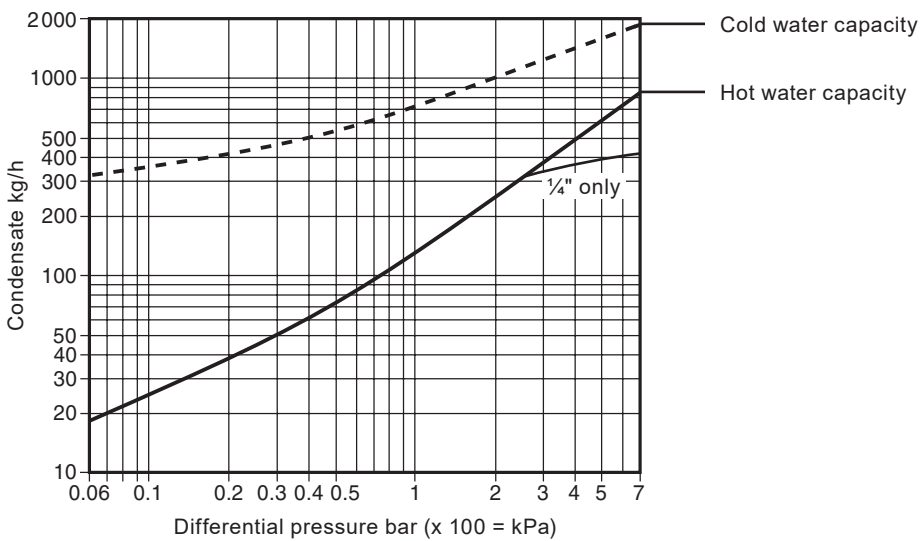

Dimensions/weights (approximate) in mm and kg

Size	A	B	C	D	Weight	
	Tube	Tube	Tube	Screwed	Tube	Screwed
1/4"	40	-	-	58	-	0.53
1/2"	40	106	40	74	0.44	0.49
3/4"	40	106	40	81	0.51	0.60
1"	40	106	40	95	0.60	0.73
DN8*	40	106	40	-	0.35	-
DN10	40	106	40	-	0.35	-
DN15	40	106	40	-	0.42	-

*DN8 only available for ISO 1127 tube ends.

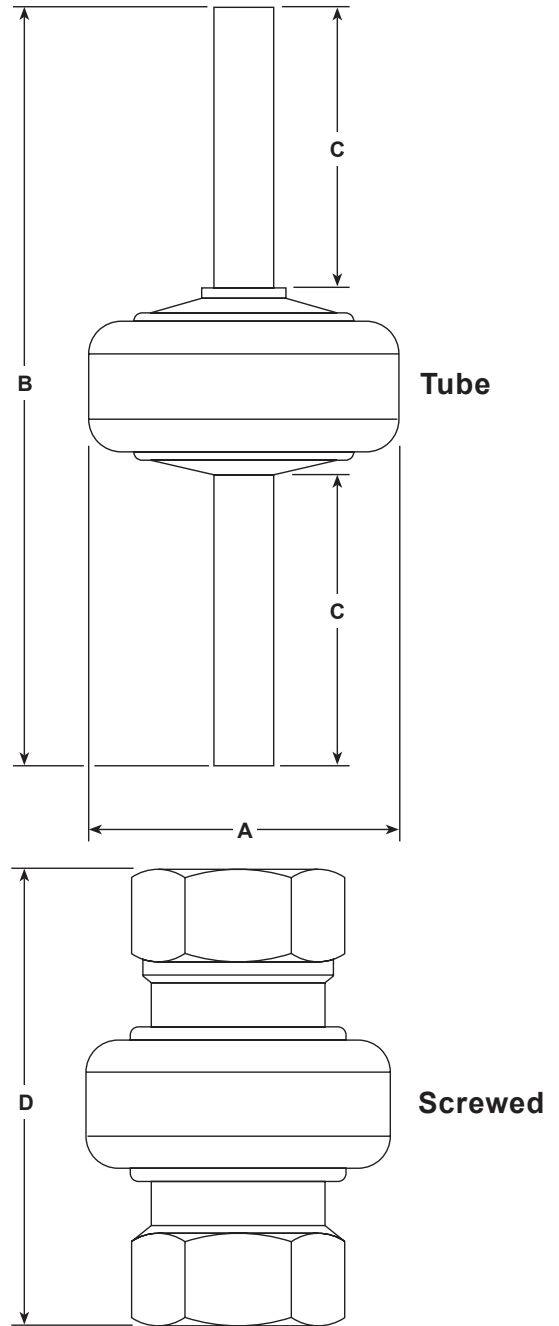

Safety information, installation and maintenance

For full details see the Installation and Maintenance Instructions (IM-P180-05) supplied with the product.

Installation note:

The trap is designed for installation in vertical lines with the flow downward to ensure self-draining operation. Do not expose the element to superheat conditions since over-expansion may result.

Suitable isolation valves must be installed to allow for safe maintenance/replacement.

How to order

Example: 1 off Spirax Sarco non-maintainable DN15 BTS7 clean steam trap with tube ends to ISO 1127, Series 1. (21.3 mm O/D x 1.6 mm wall thickness). Tangent length of tube ends to be 40 mm for ease of orbital welding. Body to be self-draining. Suitable for pressures up to 7 bar g.

Spare parts

There are no spare parts for the BTS7.