

# 120W / 120WC Cast Iron Swing Check Valve • Spec Sheet

Sizes 3" - 12"

## FEATURES & BENEFITS

- ISO 9002
- Class 125 Cast Iron
- 200 PSI Non-Shock CWP
- Bolted Cover
- Bronze Seat & Resilient Disc
- Outside Lever & Weight or Optional Spring Kit Available
- Fusion Bonded Epoxy Coating Inside & Outside – AWWA C550
- MSS SP 71 Compliant
- AWWA C508 Approved
- Flanged Ends Conform with ANSI B16.1
- For Horizontal & Vertical Installation

**Applications:** Wastewater & Sewage, Irrigation, Potable Water, Turf, Golf Course, Water Distribution



\*120W is Less Outside Lever & Weight

## MATERIAL SPECIFICATIONS

No.	Part	Material	ASTM Designation
1	Body	Cast Iron	A 126 Class B
2	Disc	Ductile Iron	A 536 Gr. 64-45-12
3	Cover	Ductile Iron	A 536 Gr. 64-45-12
4	Weight	Cast Iron	A 126 Class B
5	Arm	Ductile Iron	A 536 Gr. 64-45-12
6	Seat Holder 3"-6"	Cast Iron	-----
6	Seat Holder 8"-12"	Ductile Iron	-----
7	Body Seat Ring	Stainless Steel	A 276 Type 316
8	Disc Seat Ring	Rubber (BUNA-N)	D 2000 BK 707
9	Seat Nut	Brass	B 21
10	Bushing	Bronze	B 62 Alloy C83600
11	Bolt & Nut	Zinc Coated Steel	A 307 Grade B
12	Weight Arm	Ductile Iron	A 536 Gr. 64-45-12
13	Hinge Pin	Stainless Steel	A 276 Type 316
14	Key	Stainless Steel	A 276 Type 304
15	Plug	Stainless Steel	A 276 Type 304
16	Pin	Stainless Steel	A 276 Type 304
17	Disc Seat Bolt	Stainless Steel	Type SS 316
18	Weight Bolt & Nut	Stainless Steel	Type SS 316
19	Snap Ring	Stainless Steel	-----
20	Disc Stud	Brass	B 21
21	Disc Nut	Brass	B 21
22	Spacer	Brass	B 21
23	Washer	Brass	B 21
24	Cover Bolt	Stainless Steel	Type SS 316
25	Gasket	Rubber (BUNA-N)	D 2000 BK 707
26	O-Ring B	Rubber (BUNA-N)	D 2000 BK 707
27	O-Ring C	Rubber (BUNA-N)	D 2000 BK 707
28	Retaining Plug	Brass	B 21

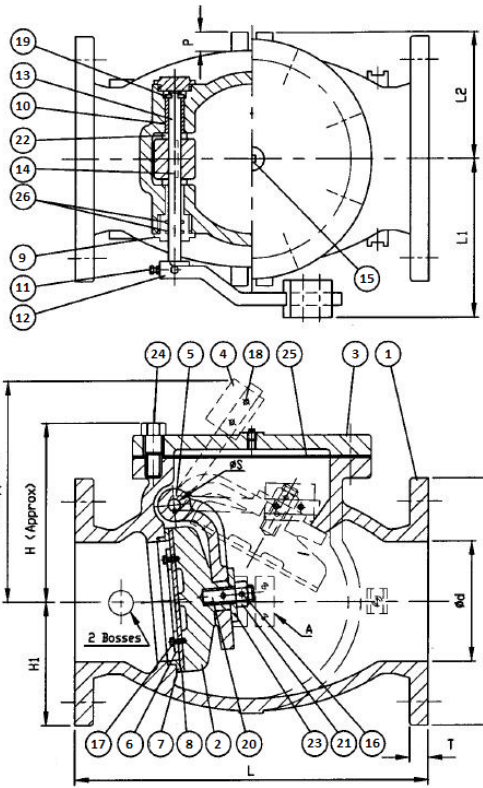

Valve Size	Plug Size
3"	1/2
4"	1/2
6"	3/4
8"	3/4
10"	1
12"	1

Click Here For Enlarged Drawing

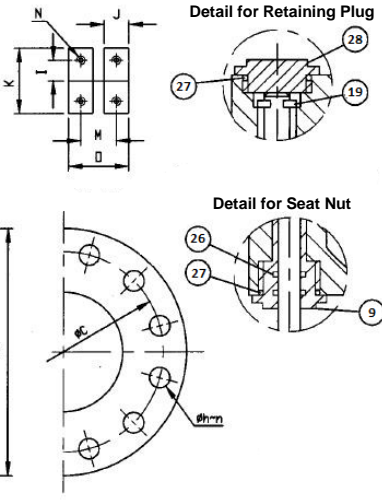

## DIMENSIONS

Size Ød	L	ØD	ØC	Øh	n	T	ØS	H	H1	H2	I	J	K	M	N	O	P	L1	L2
3"	9-1/2	7-1/2	6	3/4	4	3/4	1/2	6-1/16	3-3/4	9-1/4	3/4	1-1/2	3	2-1/2	1/2 X 13TPI(UNC)	4	3/4	6-5/16	4-1/16
4"	11-1/2	9	7-1/2	3/4	8	15/16	1/2	6-7/8	4-1/2	11-13/16	3/4	1-1/2	3	2-1/2	1/2 X 13TPI(UNC)	4	3/4	7-1/8	4-15/16
6"	14	11	9-1/2	7/8	8	1	3/4	8-1/2	5-1/2	14-3/8	3/4	1-1/2	3	2-1/2	1/2 X 13TPI(UNC)	4	3/4	8-11/16	5-15/16
8"	19-1/2	13-1/2	11-3/4	7/8	8	1-1/8	7/8	9-15/16	6-3/4	17-3/8	7/8	1-3/4	3-1/2	3-1/4	5/8 X 11TPI(UNC)	5	1-1/4	10-7/8	8-1/16
10"	24-1/2	16	14-1/4	1	12	1-3/16	1	11-3/16	8	21-1/2	7/8	1-3/4	3-1/2	3-1/4	5/8 X 11TPI(UNC)	5	1-1/4	12-1/4	9-3/16
12"	27-1/2	19	17	1	12	1-1/4	1-1/8	13-9/16	9-1/2	24-1/16	7/8	1-3/4	3-1/2	3-1/4	5/8 X 11TPI(UNC)	5	1-1/4	14-3/8	10-13/16

# 120W / 120WC Cast Iron Swing Check Valve • Spec Sheet

Sizes 3" - 12"

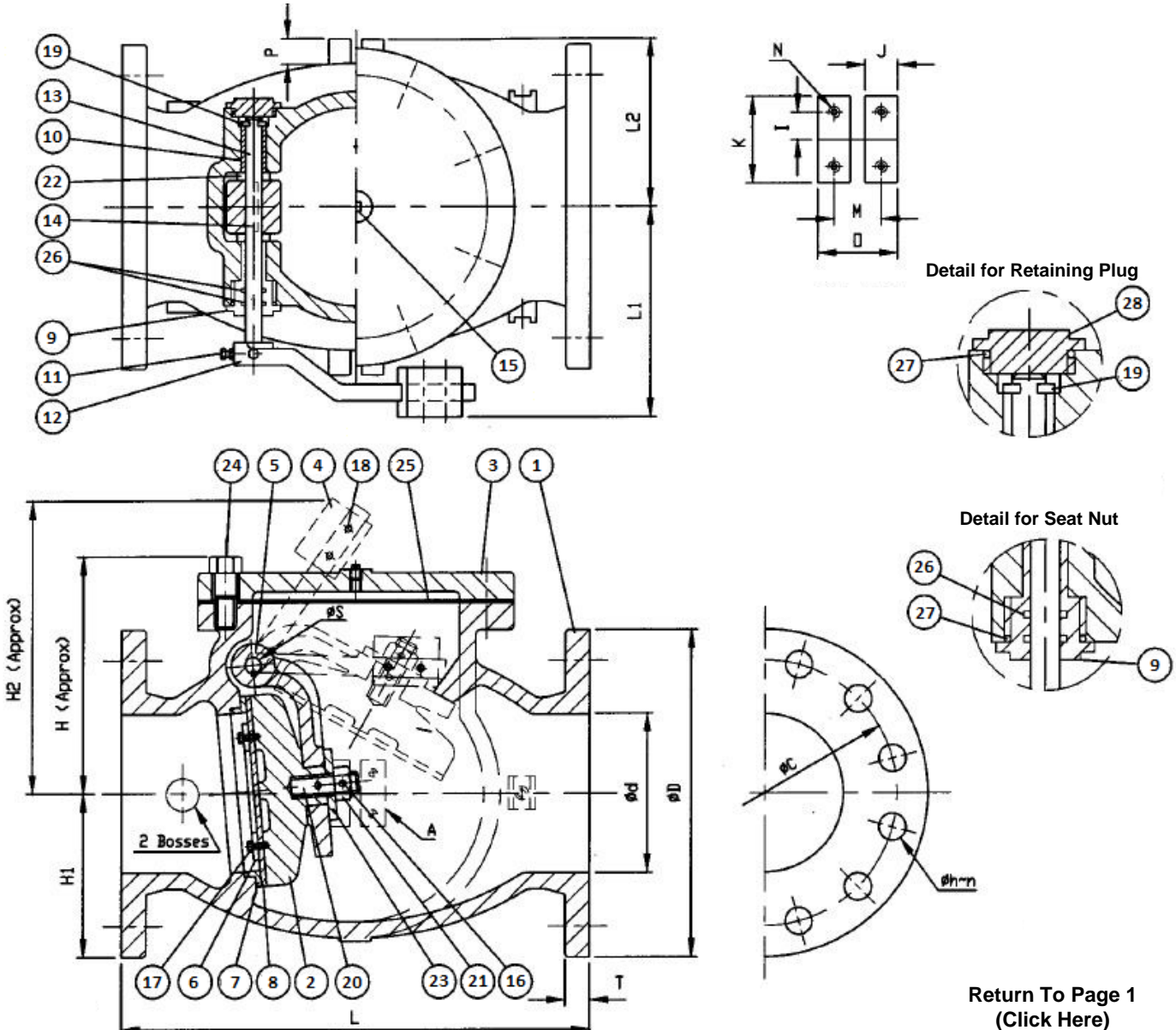

Return To Page 1  
(Click Here)

**MATCO-NORCA**  
Global sourcing. National compliance. Local service.

**CALIFORNIA** 5593 Fresca Dr., La Palma CA 90623 • Toll Free: 866-532-8306 • Fax: 866-532-8307  
**TEXAS** 1150 Silber Rd., Houston TX 77055 • Toll Free: 800-935-5456 • Fax: 713-680-2999  
**NEW YORK** PO Box 27, Rt. 22, Brewster NY 10509 • Toll Free: 800-431-2082 • Fax: 845-278-9056  
 WEB: [www.matco-norca.com](http://www.matco-norca.com) EMAIL: [mail@matco-norca.com](mailto:mail@matco-norca.com)

# 120WC Cast Iron Swing Check Valve • Spec Sheet

Sizes 14" & 16"

## FEATURES & BENEFITS

- ISO 9002
- Class 125 Cast Iron
- 200 PSI Non-Shock CWP
- Bolted Cover
- Bronze Seat & Resilient Disc
- Outside Lever & Weight or Optional Spring Kit Available
- Fusion Bonded Epoxy Coating Inside & Outside – AWWA C550
- MSS SP 71 Compliant
- AWWA C508 Approved
- Flanged Ends Conform with ANSI B16.1
- For Horizontal & Vertical Installation

**Applications:** Wastewater & Sewage, Irrigation, Potable Water, Turf, Golf Course, Water Distribution

## MATERIAL SPECIFICATIONS

No.	Part	Material	ASTM Designation
1	Body	Cast Iron	A 126 Class B
2	Disc	Ductile Iron	A 536 Gr. 64-45-12
3	Cover	Cast Iron	A 126 Class B
4	End Plate (A)	Bronze	B 62 Alloy C83600
5	Weight	Cast Iron	A 126 Class B
6	Seat Holder	Ductile Iron	A 536 Gr. 64-45-12
7	End Plate (B)	Ductile Iron	A 536 Gr. 64-45-12
8	Body Seat Ring	Bronze	B 62 Alloy C83600
9	Disc Seat Ring	Rubber (BUNA-N)	D 2000 BK 707
10	Bushing (A)	Bronze	A 126 Class B
11	Bushing (B)	Bronze	A 126 Class B
12	Weight Arm	Ductile Iron	A 536 Gr. 64-45-12
13	Hinge Pin	Stainless Steel	A 276 Type 316
14	Key	Stainless Steel	A 276 Type 304
15	Plug	Stainless Steel	A 276 Type 304
16	Disc Seat Bolt	Stainless Steel	Type SS 316
17	Cover Bolt & Nut	Stainless Steel	Type SS 316
18	Weight Bolt	Stainless Steel	Type SS 316
19	End Plate	Zinc Coated Steel	A 307 Grade B
20	Snap Ring	Stainless Steel	-----
21	Cover Gasket	Rubber (BUNA-N)	D 2000 BK 707
22	O-Ring B	Rubber (BUNA-N)	D 2000 BK 707
23	O-Ring C	Rubber (BUNA-N)	D 2000 BK 707

[Click Here For Enlarged Drawing](#)

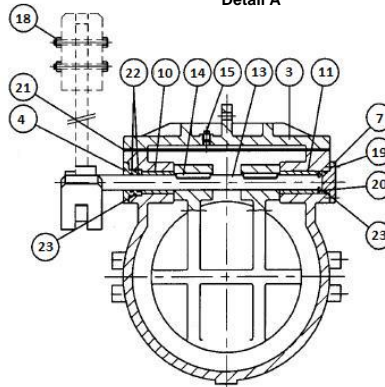
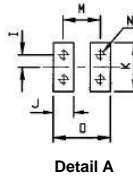

## DIMENSIONS

Size Ød	L	ØD	ØC	Øh	n	T	ØS	ØB	H	H1	I	J	K	M	N	O
14"	31	21	18-3/4	1-1/8	12	1-3/8	1-3/4	22-3/16	19-5/16	12-1/6	1	2-1/8	4-1/2	4	3/4 X 10TPI(UNC)	6
16"	36	23-1/2	21-1/4	1-1/8	16	1-7/16	2	24-1/8	21-1/2	13-1/4	1	2-1/8	4-1/2	4	3/4 X 10TPI(UNC)	6

# 120WC Cast Iron Swing Check Valve • Spec Sheet

Sizes 14" & 16"

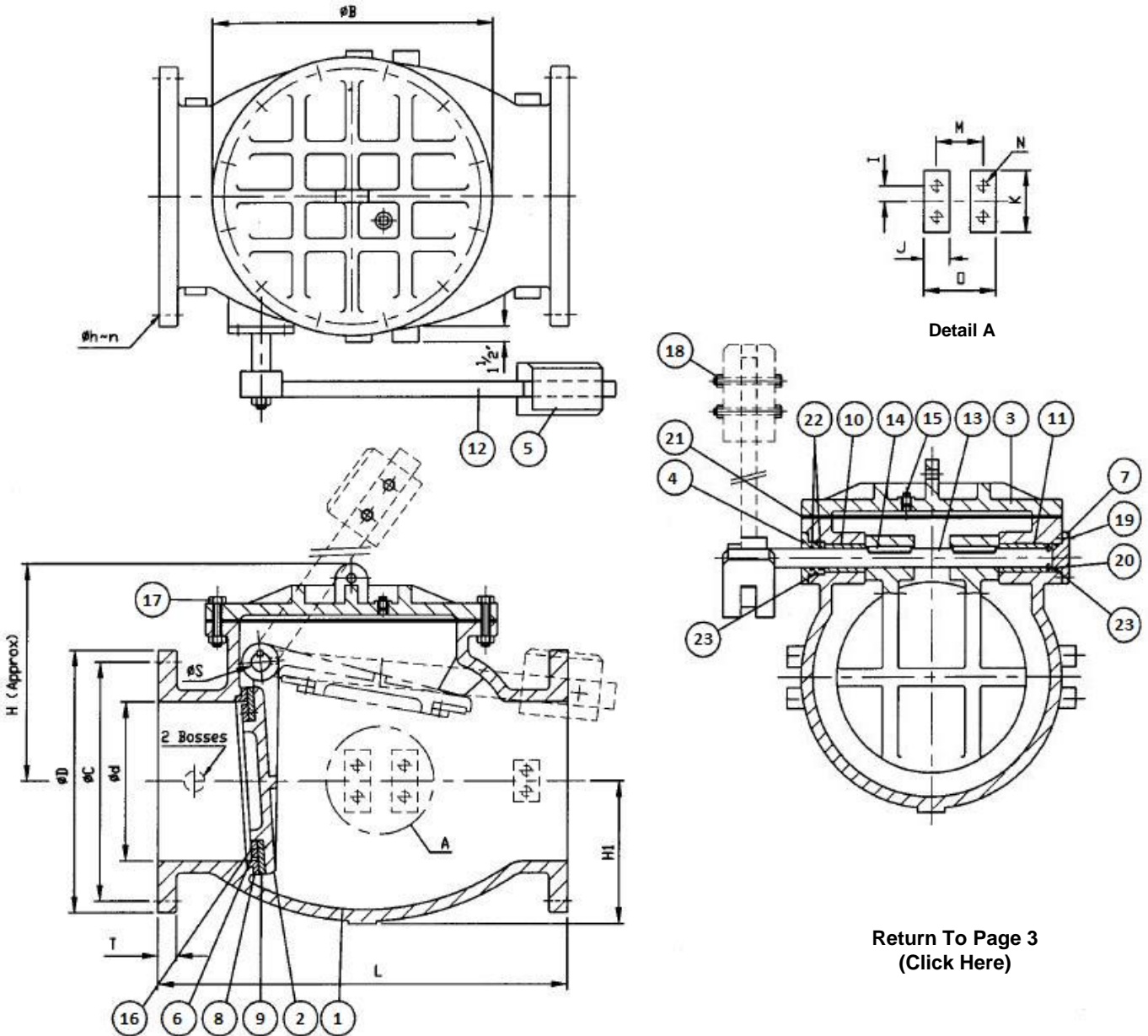

Return To Page 3  
(Click Here)

 **MATCO-NORCA**  
Global sourcing. National compliance. Local service.

**CALIFORNIA** 5593 Fresca Dr., La Palma CA 90623 • Toll Free: 866-532-8306 • Fax: 866-532-8307  
**TEXAS** 1150 Silber Rd., Houston TX 77055 • Toll Free: 800-935-5456 • Fax: 713-680-2999  
**NEW YORK** PO Box 27, Rt. 22, Brewster NY 10509 • Toll Free: 800-431-2082 • Fax: 845-278-9056  
 WEB: [www.matco-norca.com](http://www.matco-norca.com) EMAIL: [mail@matco-norca.com](mailto:mail@matco-norca.com)