

FIG. CV890

Dual Disc Check Valve



The Figure CV890 Dual Disc Check Valve is a grooved end, dual disc check valve used for pipelines to convey water and other fluids with a rated working pressure up to 300 psi (20.7 bar). This Dual Disc Check Valve is available in sizes from 14 inches (350 mm) to 24 inches (600 mm).

The Figure CV890 Dual Disc Check Valve features a fully lined rubber body, spring-loaded 304 stainless steel disc and shafts. The Dual Disc Check Valve can be installed in a horizontal or vertical position (upward flow only). A lifting lug is provided with the assembly for ease of handling. The face to face dimensions conforms to API 594 Class 150 and grooved end dimensions to ANSI/AWWA C606. The seat and shell pressure tests conform to MSS SP-136 or higher.

The Figure CV890 Dual Disc Check Valve is lighter than conventional swing check valves and is easier to install, utilizing only two grooved couplings. It is more economical than wafer or lugged valves. The Dual Disc Check Valve design produces less water hammer than a single disc valve. The spring-loaded disc design provides for positive closing. The fully lined rubber body and soft seat reduces noise and maintenance.

MAXIMUM WORKING PRESSURE: 300 psi (20.7 bar) @ 100°F (38°C)

MATERIAL SPECIFICATIONS

BODY: Ductile iron conforming to ASTM A536, Gr. 65-45-12

BODY LINING:

- Grade Nitrile – For service temperatures from -20°F to 230°F (-29°C to 110°C). Recommended for petroleum products, mineral oils, vegetable oils, aromatic hydrocarbons, acids and water $\leq 150^{\circ}\text{F}$ (+65°C).

Note: Not recommended for use in hot water services.

- Grade EPDM – For service temperatures from -30°F to 230°F (-34°C to 110°C). For general service. Recommended for water service, dilute acids, alkalies, oil-free air and many chemical services.

Note: Not recommended for use in petroleum services.

DISC: Stainless Steel Type 304

DISC SHAFTS: Stainless Steel Type 304

SPRING: Stainless Steel Type 304

PROJECT INFORMATION		APPROVAL STAMP	
Project:		<input type="checkbox"/> Approved	
Address:		<input type="checkbox"/> Approved as noted	
Contractor:		<input type="checkbox"/> Not approved	
Engineer:		Remarks:	
Submittal Date:			
Notes 1:			
Notes 2:			

FIG. CV890

Dual Disc Check Valve

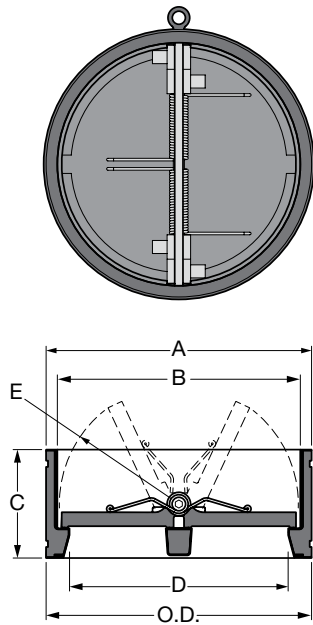

CV890 DUAL DISC CHECK VALVE							
Valve Size	O.D.	Dimensions					Approx. Wt. Ea.
		A	B	C	D	E	
in./mm	in./mm	in./mm	in./mm	in./mm	in./mm	in./mm	Lbs./Kg
14	14.00	14.49	12.96	7.25	11.14	6.06	101
350	355.6	368	329	184	283	154	46
16	16.00	16.14	14.13	7.50	12.20	6.81	119
400	406.4	410	359	191	310	173	54
18	18.00	18.15	16.42	8.000	14.33	8.00	169
450	457.2	461	417	203	364	203	77
20	20.00	20.04	18.11	8.625	16.06	8.80	211
500	508.0	509	460	219	408	226	96
24	24.00	24.00	22.13	8.750	18.00	9.80	131
600	609.6	610	562	222	457	249	288

INSTALLATION

To prevent rotation of the valve, it is recommended that the Gruvlok Figure CV890 Dual Disc Check Valve be installed with rigid couplings, such as the Figure 772 Coupling. If flexible couplings are used, additional support may be needed to prevent rotation.

Placing a Dual Disc Check Valve too close to the source of an unstable flow may shorten the life of the valve and may, potentially, damage the system. To extend the life of the Dual Disc Check Valve, the valve should be installed a reasonable distance away (downstream) from the pumps, elbows, expanders, reducers, or other similar devices. Sound piping practices dictate a minimum of five times the pipe diameter for general use. Installing the check valve a distance of three to five times the pipe diameter is allowable so long as the flow velocity is less than 8 ft/sec. Distances less than three times the pipe diameter is not recommended.

For horizontal installations, the Dual Disc Check Valve must be positioned such that the discs activate bi-symmetrically, as shown in the following drawings.

FIGURE CV890 DUAL DISC CHECK VALVE HORIZONTAL INSTALLATION

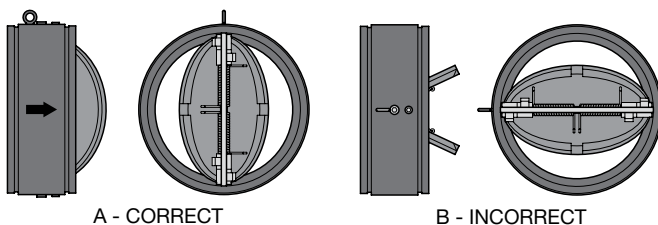

A - CORRECT

B - INCORRECT

FIGURE CV890 DUAL DISC CHECK VALVE
NOMINAL PRESSURE LOSS VS FLOW

