

88A-700 SERIES

Carbon Steel ASME Class 300 Flanged Std. Port Ball Valve - 1.5" through 2"

For **STANDARDS COMPLIANCE** and **STANDARD FEATURES** refer to page D-3.



STANDARD MATERIAL LIST

PART	MATERIAL	
1	Body	ASTM A216 WCB
2	Retainer	ASTM A108 Type 1215
3	Ball	ASTM A108, Carbon Steel, Chrome Plated or ASTM A276, Type 316 Stainless Steel
4	Stem	ASTM A108 Type 1215
5	Packing Gland	ASTM A108 Type 1215
6	Stem Seals	PTFE
7	Seats	RPTFE
8	Gland Screws	ASTM A193 B7
9	Gland Plate	302 & 304 SS
10	Stem Nut	316 SS
11	Lever	ASTM A366 Steel with Vinyl Grip
12	Stem Bearing	RPTFE
13	Stop	ASTM A108 Type 1215
14	Stop Screw	SAE J429 Grade 2
15	Lock Plate	ASTM A366 Steel
16	Body Seal	RPTFE
17	Lockwasher	302 or 304 SS
18	Grounding Spring	SS

VARIATIONS AVAILABLE:

88A-740 Series (316 SS Ball & Stem)

88A-730 Series (Ni-Cu Ball & Stem)

OPTIONS AVAILABLE: (More information in Section J)

- Minimum quantities apply
- To specify an option, replace the "01" standard suffix with the suffix of the option.
- To specify multiple options, replace the "01" suffix with the desired suffixes in the numerical order shown below. NOTE: Not all suffixes can be combined together.

(SUFFIX)	OPTION
-01	Standard Configuration
-04-	2.25" Stem Extension (Carbon Steel, Zinc Plated)
-10-	SS Lever and Nut
-14-	Side Vented Ball (Uni-Directional). Not available with plated CS ball.
-15-	Wheel Handle, Steel
-21-	UHMWPE Seats
-24-	Graphite packing, spiral wound graphite body seal, RPTFE bearing (API 607, 5th edition, ISO 10497-5:2004)
-26-	Chlorine Service. Vented. Special Cleaning. Assembled dry. (for CS, Hastelloy and Ni-Cu valves. Ball must be Hastelloy or Ni-CU)
-35-	PTFE Seats and Seals
-38-	PEEK Seats and Graphite Packing
-49-	No Lubrication. Assembled Dry.
-65-	MPTFE Seats and Graphite Packing (Fire Safe)
-67-	Cleaned For Industrial Gases
-69-	Drilled and Tapped Purge Ports with Plugs
-70-	4" Extended Bonnet
-73-	316 SS Spiral Wound Gaskets w/PTFE Filler
-76-	Live Loaded (Lever)
-77-	Live Loaded (Gear, Actuator)
-80-	Multi-Seal (Super TFE)
-82-	Flat Face Flanges
-90-	Double Packed 4" Extended Bonnet
-9P-	Double Packed 4" Extended Bonnet with Monitoring Port
-EP-	Garlock EVSP Stem Packing w/Spiral Wound Graphite Gasket (Fire Safe by Design)
-KF-	PCTFE Stem Bearing
-TC-	With Test Certificate
-TD-	Tested to API Spec 6D
-UL-	UL & CSA Listed (w/Markings)

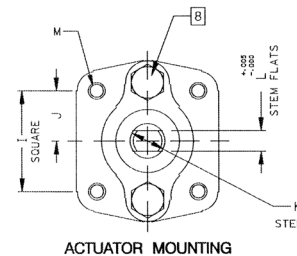
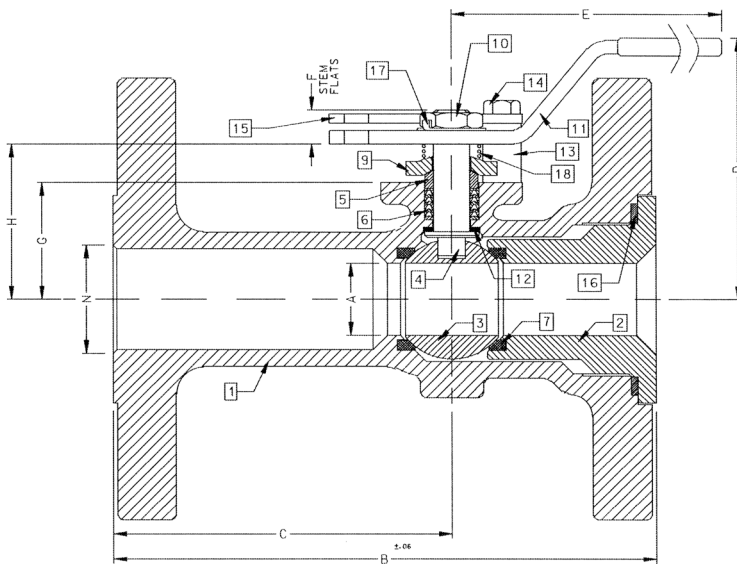

FOR PRESSURE/TEMPERATURE RATINGS, REFER TO PAGE M-11, GRAPH NO. 5

PRODUCT NUMBER	SIZE	A	B	C	D	E	F	G	H	I	J	K	L	M	N	WT.
88A-707-01	1.5"	1.25	7.50	4.50	4.85	6.53	0.47	1.85	2.38	1.392	0.696	0.500	0.287	1/4-20	1.50	16
88A-708-01	2"	1.50	8.50	5.19	4.62	6.65	0.72	2.41	3.09	1.949	0.974	0.625	0.412	5/16-18	2.00	24



88A-700 SERIES

Carbon Steel ASME Class 300 Flanged Std. Port Ball Valve - 2.5" through 3"

For **STANDARDS COMPLIANCE** and **STANDARD FEATURES** refer to page D-3.



STANDARD MATERIAL LIST

PART	MATERIAL	
1	Body	ASTM A216 WCB
2	Retainer	ASTM A216 WCB
3	Ball	ASTM A108 Type 1215 or A216 WCB Chrome Plated
4	Stem	ASTM A108 Type 1215
5	Packing Gland	ASTM A108 Type 1215
6	Stem Seals	PTFE
7	Seats	RPTFE
8	Gland Screws	ASTM A193 B7
9	Gland Plate	302 or 304 SS
10	Stem Nut	ASTM A194 Grade 8
11	Lever	ASTM A366 Steel with Vinyl Grip
12	Stem Bearing	RPTFE
13	Stop	ASTM A108 Type 1215
14	Stop Screw	SAE J429 Grade 2
15	Lock Plate	ASTM A366 Steel
16	Body Seal	RPTFE
17	Grounding Spring	SS
18	Body Joint Stud	ASTM A193 Grade B7
19	Body Joint Nut	ASTM A194 Grade 2H
20	Lockwasher	302 or 304 SS

VARIATIONS AVAILABLE:

88A-740 Series (316 SS Ball & Stem)

88A-730 Series (Ni-Cu Ball & Stem)

OPTIONS AVAILABLE: (More information in Section J)

- Minimum quantities apply
- To specify an option, replace the "01" standard suffix with the suffix of the option.
- To specify multiple options, replace the "01" suffix with the desired suffixes in the numerical order shown below. NOTE: Not all suffixes can be combined together.

(SUFFIX)	OPTION
-01	Standard Configuration
-04-	2.25" Stem Extension (Carbon Steel, Zinc Plated)
-10-	SS Lever and Nut
-14-	Side Vented Ball (Uni-Directional). Not available with plated CS ball.
-15-	Wheel Handle, Steel
-21-	UHMWPE Seats
-24-	Graphite packing, spiral wound graphite body seal, RPTFE bearing (API 607, 6th edition, ISO 10497:2010)
-26-	Chlorine Service. Vented. Special Cleaning. Assembled dry. (for CS, Hastelloy and Ni-Cu valves. Ball must be Hastelloy or Ni-CU)
-35-	PTFE Seats and Seals
-38-	PEEK Seats and Graphite Packing
-49-	No Lubrication. Assembled Dry.
-59-	SS External Trim
-65-	MPTFE Seats and Graphite Packing (Fire Safe)
-67-	Cleaned For Industrial Gases
-69-	Drilled and Tapped Purge Port with Plug
-70-	4" Extended Bonnet
-73-	316 SS Spiral Wound Gaskets w/PTFE Filler
-76-	Live Loaded (Lever)
-77-	Live Loaded (Gear, Actuator)
-80-	Multi-Seal (Super TFE)
-82-	Flat Face Flanges
-90-	Double Packed 4" Extended Bonnet
-9P-	Double Packed 4" Extended Bonnet with Monitoring Port
-EP-	Garlock EVSP Stem Packing w/Spiral Wound Graphite Gasket (Fire Safe by Design)
-KF-	PCTFE Stem Bearing
-MG-	Gear Operator with Standard Handwheel
-MH-	Gear Operator with Standard Handwheel & Locking Device
-MJ-	Gear Operator with Oversize Handwheel
-MK-	Gear Operator with Oversize Handwheel & Locking Device
-TC-	With Test Certificate
-TD-	Tested to API Spec 6D
-UL-	UL & CSA Listed (w/Markings)

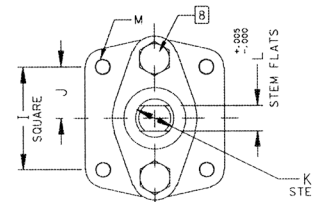
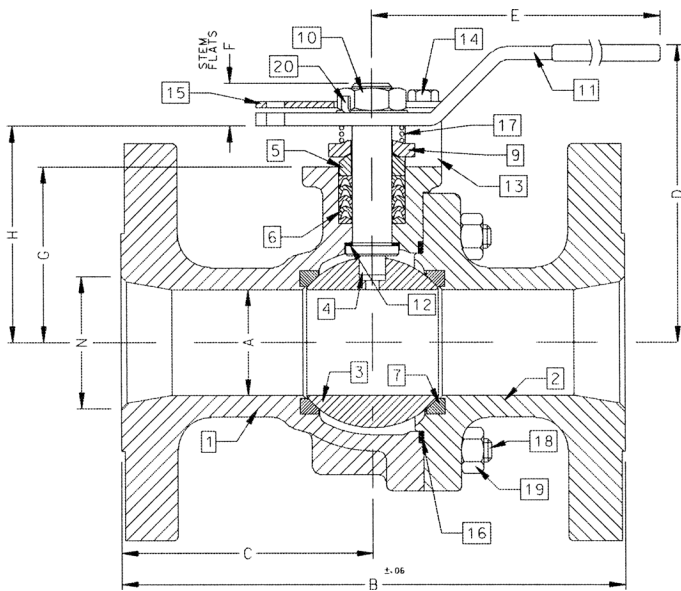

ACTUATOR MOUNTING

FOR PRESSURE/TEMPERATURE RATINGS, REFER TO PAGE M-11, GRAPH NO. 5

PRODUCT NUMBER	SIZE	A	B	C	D	E	F	G	H	I	J	K	L	M	N	WT.
88A-709-01	2.5"	2.00	9.50	4.75	5.61	8.41	0.80	3.31	4.08	1.949	0.974	0.750	0.477	5/16-18	2.50	39
88A-700-01	3"	2.50	11.12	5.56	6.24	8.41	0.80	3.94	4.71	1.949	0.974	0.750	0.477	5/16-18	3.00	55

88A-700 SERIES

Carbon Steel ASME Class 300 Flanged Std. Port Ball Valve - 4" through 8"

For **STANDARDS COMPLIANCE** and **STANDARD FEATURES** refer to page D-3.



STANDARD MATERIAL LIST

PART	MATERIAL	
1	Body	ASTM A216 WCB
2	Retainer	ASTM A216 WCB
3	Ball	ASTM A108 Type 1215 or A216 WCB Chrome Plated
4	Stem	ASTM A108 Type 1215
5	Packing Gland	ASTM A108 Type 1215
6	Stem Seals	PTFE
7	Seats	RPTFE
8	Gland Screws	ASTM A193 B7
9	Gland Plate	316 SS
10	Adapter Screw	316 SS
11	Handle Adapter	ASTM A366 Steel with Vinyl Grip
12	Stem Bearing	RPTFE
13	Stop	ASTM A108 Type 1215
14	Stop Screw	SAE J429 Grade 2
15	Lock Plate	ASTM A366 Steel
16	Body Seal	RPTFE
17	Grounding Spring	SS
18	Body Joint Stud	ASTM A193 Grade B7
19	Body Joint Nut	ASTM A194 Grade 2H
20	Adapter Screw	316 SS
21	Pipe Handle	Galvanized Steel (not shown)

VARIATIONS AVAILABLE:

88A-740 Series (316 SS Ball & Stem)

88A-730 Series (Ni-Cu Ball & Stem)

OPTIONS AVAILABLE: (More information in Section J)

- Minimum quantities apply
- To specify an option, replace the "01" standard suffix with the suffix of the option.
- To specify multiple options, replace the "01" suffix with the desired suffixes in the numerical order shown below. NOTE: Not all suffixes can be combined together.

(SUFFIX)	OPTION
-01	Standard Configuration
-14-	Side Vented Ball (Uni-Directional). Not available with plated CS ball.
-21-	UHMWPE Seats
-24-	Fire Safe - graphite packing & seals (API 607, 5th edition, ISO 10497-5:2004) 4" & 6" (API 607, 6th edition, ISO 10497:2010) 8"
-26-	Chlorine Service. Vented. Special Cleaning. Assembled dry. (for CS, Hastelloy and Ni-Cu valves. Ball must be Hastelloy or Ni-CU)
-35-	PTFE Seats and Seals
-49-	No Lubrication. Assembled Dry.
-59-	SS External Trim
-65-	MPTFE Seats and Graphite Packing (Fire Safe)
-67-	Cleaned For Industrial Gases
-69-	Drilled and Tapped Purge Ports with Plugs
-70-	4" Extended Bonnet
-73-	316 SS Spiral Wound Gaskets w/PTFE Filler
-76-	Live Loaded (Lever)
-77-	Live Loaded (Gear, Actuator)
-80-	Multi-Seal (Super TFE)
-82-	Flat Face Flanges
-90-	Double Packed 4" Extended Bonnet
-9P-	Double Packed 4" Extended Bonnet with Monitoring Port
-EP-	Garlock EVSP Stem Packing w/Spiral Wound Graphite Gasket (Fire Safe by Design)
-KF-	PCTFE Stem Bearing
-MG-	Gear Operator with Standard Handwheel
-MH-	Gear Operator with Standard Handwheel & Locking Device
-MJ-	Gear Operator with Oversize Handwheel
-MK-	Gear Operator with Oversize Handwheel & Locking Device
-TC-	With Test Certificate
-TD-	Tested to API Spec 6D
-UL-	UL & CSA Listed (w/Markings)

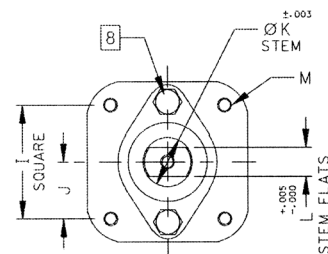
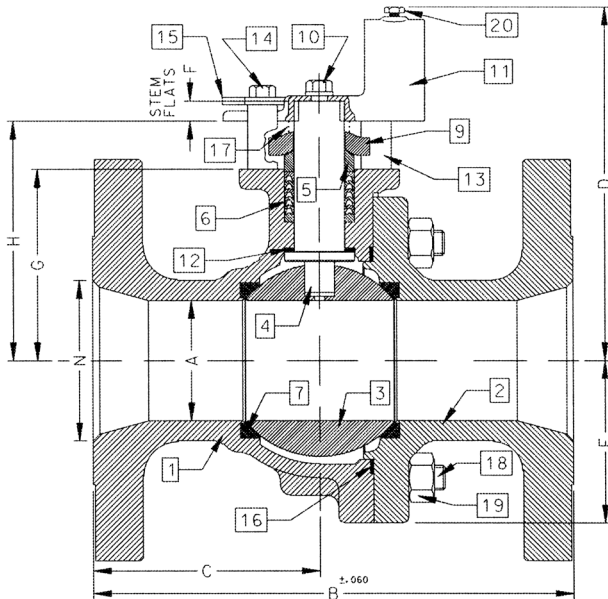

ACTUATOR MOUNTING

FOR PRESSURE/TEMPERATURE RATINGS, REFER TO PAGE M-11, GRAPH NO. 5

PRODUCT NUMBER	SIZE	A	B	C	D	E	F	G	H	I	J	K	L	M	N	WT.
88A-70A-01	4"	3.00	12.00	5.68	8.80	4.06	0.50	4.75	5.95	2.840	1.420	1.250	0.725	3/8-16	4.00	95
88A-70C-01	6"	4.00	15.88	7.38	9.99	5.25	0.50	5.94	7.13	2.840	1.420	1.250	0.725	3/8-16	6.00	187
88A-70E-01	8"	6.00	19.75	9.00	13.73	7.30	1.00	7.75	9.48	4.596	2.298	2.000	1.375	3/4-10	8.00	400



88A-700 SERIES

Carbon Steel ASME Class 300 Flanged Std. Port Ball Valve - 10"

For **STANDARDS COMPLIANCE** and **STANDARD FEATURES** refer to page D-3.



STANDARD MATERIAL LIST

PART	MATERIAL
1 Body	ASTM A216 WCB
2 Retainer	ASTM A216 WCB
3 Ball	ASTM A108 Type 1215 or A216 WCB Chrome Plated
4 Stem	ASTM A108 Type 1215
5 Packing Gland	ASTM A108 Type 1215
6 Stem Seals	PTFE
7 Seats	RPTFE
8 Gland Screws	ASTM A193 B7
9 Gland Plate	316 SS
10 Stem Bearing	RPTFE
11 Body Seal	RPTFE
12 Body Joint Stud	ASTM A193 Grade B7
13 Body Joint Nut	ASTM A194 Grade 2H

VARIATIONS AVAILABLE:

88A-730 Series (Ni-Cu Ball & Stem)
88A-740 Series (316 SS Ball & Stem)

OPTIONS AVAILABLE: (More information in Section J)

- Minimum quantities apply
- To specify an option, replace the "01" standard suffix with the suffix of the option.
- To specify multiple options, replace the "01" suffix with the desired suffixes in the numerical order shown below. NOTE: Not all suffixes can be combined together.

(SUFFIX)	OPTION
-01	Standard Configuration
-14-	Side Vented Ball (Uni-Directional). Not available with plated CS ball.
-21-	UHMWPE Seats
-24-	Graphite packing, spiral wound graphite body seal, RPTFE bearing (API 607, 5th edition, ISO 10497-5:2004) Chlorine Service. Vented. Special Cleaning. Assembled dry. (for CS, Hastelloy and Ni-Cu valves. Ball must be Hastelloy or Ni-CU)
-26-	PTFE Seats and Seals
-35-	No Lubrication. Assembled Dry.
-49-	MPTFE Seats and Graphite Packing (Fire Safe)
-67-	Cleaned For Industrial Gases
-69-	Drilled and Tapped Purge Port with Plugs
-70-	4" Extended Bonnet
-77-	Live Loaded (Gear, Actuator)
-80-	Multi-Seal (Super TFE)
-82-	Flat Face Flanges
-90-	Double Packed 4" Extended Bonnet
-9P-	Double Packed 4" Extended Bonnet with Monitoring Port
-EP-	Garlock EVSP Stem Packing w/Spiral Wound Graphite Gasket (Fire Safe by Design)
-KF-	PCTFE Stem Bearing
-MG-	Gear Operator with Standard Handwheel
-MH-	Gear Operator with Standard Handwheel & Locking Device
-MJ-	Gear Operator with Oversize Handwheel
-MK-	Gear Operator with Oversize Handwheel & Locking Device
-TC-	With Test Certificate
-TD-	Tested to API Spec 6D
-UL-	UL & CSA Listed (w/Markings)

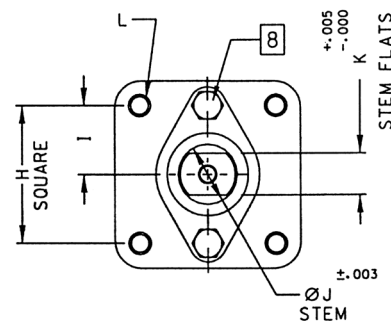
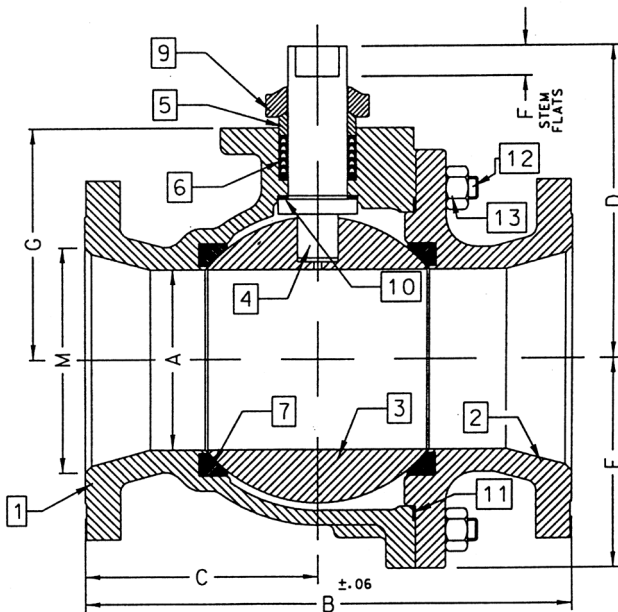

ACTUATOR MOUNTING

FOR PRESSURE/TEMPERATURE RATINGS, REFER TO PAGE M-11, GRAPH NO. 5

PRODUCT NUMBER	SIZE	A	B	C	D	E	F	G	H	I	J	K	L	M
88A-70G-01	10"	8.00	22.38	10.69	12.83	9.56	1.00	10.22	4.596	2.298	2.000	1.375	3/4-10	10.00

ASME FLANGED BALL VALVES

Features and Benefits

87A, 87A-F, 87B, 88A, 88A-F, 88B, 88L, & 88L-F Series



STANDARDS COMPLIANCE:

Except where specifically noted all valves within this family of products complies with the requirements of this listed standard.

ASME B16.5	"Pipe Flanges and Flanged Fittings"
ASME B16.10	"Face to Face Dimensions of Valves"
ASME B16.34	"Valves - Flanged, Threaded, and Welding End"
ASME B16.33	"Manual Operated Metallic Gas Valves for Use in Gas Piping Systems up to 125 psig"
ASME B16.38	"Large Metallic Valves for Gas Distribution (Manually Operated NPS 2.5" to 12", 125 psig)"
ASME B31.1	"Power Piping"
ASME B31.3	"Chemical Plant and Petroleum Refinery Piping"
ASME B31.8	"Gas Transmission and Distribution Piping Systems"
API 607	"Fire Test - Soft Seated Quarter Turn Valves" (-24 Option Required). See specific tech sheet for 5th or 6th edition.
API 608	"Ball Valves - Flanged, Threaded, and Welding End"
MSS SP-25	"Standard Marking System for Valves"
MSS SP-61	"Pressure Testing of Steel Valves"
MSS SP-72	"Ball Valves with Flanged or Buttweld Ends"
UL 125	"Valves for Anhydrous Ammonia and LP-Gas (Other than Safety Relief)"
NSF/ANSI 61	Section 8, Annex G (1/2" to 4" 87A Series)
NSF-372	Drinking Water System Components - Lead Content (1/2" to 4" 87A Series)

STANDARD FEATURES:

Except where specifically noted all valves within this family of products include all listed features as standard.

- Two Position Locking Device (Valves 6" Full Port, 8" Standard Port and smaller)
- Chevron Style Adjustable Stem Seals
- ISO 5211 Mounting Pad Bolt Pattern
- Slot Vented Ball for Thermal Expansion
- Rated up to 150 psig Saturated Steam
 - ASME Class 150, 300, & 600 Valves
- Rated up to 250 psig Saturated Steam
 - ASME Class 300 Valves Require the -65 Option
 - ASME Class 600 Valves Require the -24-80 Options or -38 Option
- Anti-static Grounded Ball and Stem
- Blow-out Proof Stem Design
- Cast Boss for Bleed / Drain Port
- Vacuum Service to 29 inches of Hg
- NACE MR0175 (2000) Compliance on all 87A/87B/88A/88B/88L Valves with SS Ball & Stem
- NACE MR0103 (2003) Compliance on all 87A/87B/88A/88B/88L Valves with SS Ball & Stem

PRODUCT APPROVALS:

CSA*	(Reference: ASME B16.33 & B16.38) ASME Class 150 & 300 only
UL*	(Reference: Control Number 195H) ASME Class 150 & 300 only
UL (YSDT)	LP-Gas Shut-Off Valves
UL (MHKZ)	Manual Valves
UL (YRBX)	Flammable Liquid Shut-Off Valves
UL (YRPV)	Gas Shut-Off Valves
UL (YQNZ)	Compressed Gas Shut-Off Valves
UL (YQAR)	Anhydrous Ammonia Shut-Off Valves

* Requires "UL" suffix for markings.



ASME FLANGED BALL VALVES

87A, 87B, 88A, 88B, & 88L Series



VARIATIONS AVAILABLE:

REFERENCE DATA:				ALLOY SERIES FLANGED BALL VALVES				
SIZE	PORT	ANSI CLASS	DIMENSIONAL DATA PAGE	STAINLESS STEEL	ALLOY 20	* HASTELLOY	* NICKEL	* NI-CU
1.5" & 2"	Standard	150	D-1	87A-10X	87A-40X	87H-1HX	87N-1NX	87M-13X
2.5" & 3"	Standard	150	D-2	87A-10X	87A-40X	87H-1HX	87N-1NX	N/A
4", 6" & 8"	Standard	150	D-3	87A-10X	87A-40X	87H-1HX	87N-1NX	N/A
10"	Standard	150	D-4	87A-10X	87A-40X	87H-1HX	87N-1NX	N/A
1/2", 3/4" & 1"	Full	150	D-5	87A-20X	87A-50X	87H-2HX	87N-2NX	87M-23X
1.5", 2" & 2.5"	Full	150	D-6	87A-20X	87A-50X	87H-2HX	87N-2NX	87M-23X
3", 4", & 6"	Full	150	D-7	87A-20X	87A-50X	87H-2HX	87N-2NX	N/A
8", 10" & 12"	Full	150	D-8	87A-20X	87A-50X	87H-2HX	87N-2NX	N/A
1.5" & 2"	Standard	300	D-9	87A-70X	87A-80X	87H-7HX	87N-7NX	N/A
2.5" & 3"	Standard	300	D-10	87A-70X	87A-80X	87H-7HX	87N-7NX	N/A
4", 6" & 8"	Standard	300	D-11	87A-70X	87A-80X	87H-7HX	87N-7NX	N/A
10"	Standard	300	D-12	87A-70X	87A-80X	87H-7HX	87N-7NX	N/A
1/2", 3/4" & 1"	Full	300	D-13	87A-90X	87A-60X	87H-9HX	87N-9NX	87M-93X
1.5", 2" & 2.5"	Full	300	D-14	87A-90X	87A-60X	87H-9HX	87N-9NX	87M-93X
3", 4", & 6"	Full	300	D-15	87A-90X	87A-60X	87H-9HX	87N-9NX	N/A
8", 10" & 12"	Full	300	D-16	87A-90X	87A-60X	87H-9HX	87N-9NX	N/A

* Minimum Quantities May Apply

ALLOY MATERIAL OF CONSTRUCTION FOR PRESSURE CONTAINING / RETAINING COMPONENTS:

ALLOY	STAINLESS STEEL	ALLOY 20	HASTELLOY*	NICKEL*	NI-CU ALLOY*
Valve Series	87A-100/200,	87A-400/500,	87H-1H0/2H0,	87N-1N0/2N0,	87M-130/230,
	87A-700/900	87A-600/800	87H-7H0/9H0	87N-7N0/9N0	87M-730/930
Body	A351-CF8M	A351-CN7M	A494-CW12MW	A494-CZ100	A494-M35-1
Retainer	A351-CF8M or	A351-CN7M or	A494-CW12MW	A494-CZ100 or	A494-M35-1 or
	A276-316	B473-N08020	or B574-C276	B160-200	B164-K400
Ball	A351-CF8M or	A351-CN7M or	A494-CW12MW	A494-CZ100 or	A494-M35-1 or
	A276-316	B473-N08020	or B574-C276	B160-200	B164-K400
Stem	A276-316	B473-N08020	B574-C276	B160-200	B164-K400
Fasteners	A193-B8M,	A193-B8M,	A193-B8M,	A193-B8M,	A193-B8M,
	A194-Gr8	A194-Gr8	A194-Gr8	A194-Gr8	A194-Gr8

* Minimum Quantities May Apply

FLOW DATA

For Apollo® Ball Valves

The listed Cv "factors" are derived from actual flow testing, in the Apollo® Ball Valve Division, Conbraco Industries, Inc., Pageland, South Carolina. These tests were completed using standard "off the shelf" valves with no special preparation and utilizing standard schedule 40 pipe. It should be understood that these factors are for the valve only and also include the connection configuration. The flow testing is done utilizing water as a fluid media and is a direct statement of the gallons of water flowed per minute with a 1 psig pressure differential across the valve/connection unit. Line pressure is not a factor. Because the Cv is a factor, the formula can be used to estimate flow of most media for valve sizing.

FLOW OF LIQUID

$$Q = C_v \sqrt{\frac{\Delta P}{SpGr}}$$

$$\text{or } \Delta P = \frac{(Q)^2 (SpGr)}{(C_v)^2}$$

Where:

Q = flow in US gpm
 ΔP = pressure drop (psig)
 SpGr = specific gravity at flowing temperature
 Cv = valve constant

FLOW OF GAS

$$Q = 1360 C_v \sqrt{\frac{(\Delta P) (P_2)}{(SpGr) (T)}}$$

$$\text{or } \Delta P = \frac{5.4 \times 10^{-7} (SpGr) (T) (Q)^2}{(C_v)^2 (P_2)}$$

Where:

Q = flow in SCFH
 ΔP = pressure drop (psig)
 SpGr = specific gravity (based on air = 1.0)
 P₂ = outlet pressure-psia (psig + 14.7)
 T = (temp. °F + 460)
 Cv = valve constant

CAUTION: The gas equation shown, is valid at very low pressure drop ratios. The gas equation is **NOT** valid when the ratio of pressure drop (ΔP) to inlet pressure (P1) exceeds 0.02.

NOTE: Only use the gas equation shown if (P1-P2)/P1 is less than 0.02.

Cv FACTORS FOR APOLLO VALVES

VALVE	SIZE (IN.)														
	1/4	3/8	1/2	3/4	1	1.25	1.5	2	2.5	3	4	6	8	10	12
70B-140 Series	8.4	7.2	15	30	43	48	84	108	190	370	670	--	--	--	--
70-100/200 Series	8.4	7.2	15	30	43	48	84	108	190	370	670	--	--	--	--
70-300/400 Series	--	--	15	30	43	48	84	108	--	--	--	--	--	--	--
70-600 Series	2.3	4.5	5.4	12	14	21	34	47	--	--	--	--	--	--	--
70-800 Series	8.4	7.2	15	30	43	48	84	--	--	--	--	--	--	--	--
71-AR Series	--	--	--	30	43	48	84	108	190	370	--	--	--	--	--
71-100/200 Series	--	--	--	30	43	48	84	108	190	370	--	--	--	--	--
72-100/900 Series	--	--	26	48	65	125	170	216	--	--	--	--	--	--	--
73A-100 Series	8.4	7.2	15	30	43	48	84	108	--	--	--	--	--	--	--
73-300/400 Series	--	--	26	48	65	125	170	216	--	--	--	--	--	--	--
74-100 Series	8.4	7.2	15	30	43	48	84	108	190	370	670	--	--	--	--
75-100 Series	8.4	7.2	15	30	43	48	84	108	190	370	670	--	--	--	--
76-AR Series	8.4	7.2	15	30	43	48	84	108	190	370	670	--	--	--	--
76F-100 Series	8.1	15	15	51	68	125	177	389	--	--	--	--	--	--	--
76FJ-100 Series	8.1	15	15	51	68	125	177	389	--	--	--	--	--	--	--
76FK-100 Series	8.1	15	15	51	68	125	177	389	--	--	--	--	--	--	--
76-100 Series	8.4	7.2	15	30	43	48	84	108	190	370	--	--	--	--	--
76-300/400 Series	--	--	26	48	65	125	170	216	--	--	--	--	--	--	--
76-600 Series	2.3	4.5	5.4	12	14	21	34	47	--	--	--	--	--	--	--
76J-100 Series	8.4	7.2	15	30	43	48	84	108	190	370	--	--	--	--	--
76J-AR Series	8.4	7.2	15	30	43	48	84	108	190	370	670	--	--	--	--
76K-100 Series	8.4	7.2	15	30	43	48	84	108	190	370	--	--	--	--	--
76K-AR Series	8.4	7.2	15	30	43	48	84	108	190	370	670	--	--	--	--
7K-100 Series	--	--	15	51	68	125	177	389	503	--	--	--	--	--	--
77-AR Series	8.1	15	15	51	68	125	177	389	--	--	--	--	--	--	--
77C-100/200 Series	4.5	7.2	16	36	68	125	177	389	503	--	--	--	--	--	--
77D-140 Series	4.5	7.2	16	36	68	125	177	389	--	--	--	--	--	--	--

continued on next page



FLOW DATA

For Apollo® Ball Valves

Cv FACTORS FOR APOLLO VALVES (continued from M-3)

VALVE	SIZE (IN.)														
	1/4	3/8	1/2	3/4	1	1.25	1.5	2	2.5	3	4	6	8	10	12
77D-640 Series	--	--	--	11	24	35	--	--	--	--	--	--	--	--	--
77G-UL Series	4.5	7.2	16	36	68	125	177	389	503	--	--	--	--	--	--
77W Series	--	--	16	36	68	125	177	389	--	--	--	--	--	--	--
77-100/200 Series	8.1	15	15	51	68	125	177	389	503	--	--	--	--	--	--
79 Series	8.5	8.5	9.8	32	44	66	148	218	440	390	--	--	--	--	--
80 Series	8.4	7.2	15	30	43	48	84	108	190	370	--	--	--	--	--
82-100/200 Series	8.1	14	26	51	68	120	170	376	510	996	1893	--	--	--	--
83A/83B Series	8.1	14	26	51	68	120	170	376	--	--	--	--	--	--	--
83R-100/200 Series	--	--	--	--	--	--	170	376	--	996	1893	--	--	--	--
86A/86B Series	8.1	14	26	51	68	120	170	376	--	--	--	--	--	--	--
86R-100/200 Series	--	--	--	--	--	--	170	376	--	996	1893	--	--	--	--
87A-100 Series	--	--	--	--	--	--	86	104	234	375	673	1099	1902	3890	--
87A-200 Series	--	--	15	19	75	--	195	410	545	1021	2016	4837	9250	15170	22390
87A-700 Series	--	--	--	--	--	--	86	104	234	375	673	1099	1902	3890	--
87A-900 Series	--	--	15	19	75	--	195	410	545	1021	2016	4837	9250	15170	22390
87A-F00 Series	--	--	--	--	75	--	195	410	545	1021	2016	4837	--	--	--
87B-100 Series	--	--	--	--	--	--	--	--	--	375	673	1099	1902	3890	--
87J-100 Series	--	--	--	--	--	--	86	104	234	375	673	1099	1902	3890	--
87J-200 Series	--	--	15	19	75	--	195	410	545	1021	2016	4837	9250	15170	22390
87J-700 Series	--	--	--	--	--	--	86	104	234	375	673	1099	1902	3890	--
87J-900 Series	--	--	15	19	75	--	195	410	545	1021	2016	4837	9250	15170	22390
87K-100 Series	--	--	--	--	--	--	86	104	234	375	673	1099	1902	3890	--
87K-200 Series	--	--	15	19	75	--	195	410	545	1021	2016	4837	9250	15170	22390
87K-700 Series	--	--	--	--	--	--	86	104	234	375	673	1099	1902	3890	--
87K-900 Series	--	--	15	19	75	--	195	410	545	1021	2016	4837	9250	15170	22390
88A-100 Series	--	--	--	--	--	--	86	104	234	375	673	1099	1902	3890	--
88A-200 Series	--	--	15	19	75	--	195	410	545	1021	2016	4837	9250	15170	22390
88A-700 Series	--	--	--	--	--	--	86	104	234	375	673	1099	1902	3890	--
88A-900 Series	--	--	15	19	75	--	195	410	545	1021	2016	4837	9250	15170	22390
88A-F00 Series	--	--	--	--	75	--	195	410	545	1021	2016	4837	--	--	--
88B-100 Series	--	--	--	--	--	--	--	--	--	375	673	1099	1902	3890	--
89-100 Series	8.4	7.2	15	30	43	48	84	108	190	370	--	--	--	--	--
9A-100 Series	8.3	6.7	5.7	10	16	25	40	62	--	--	--	--	--	--	--
90-100 Series	8.3	6.7	5.7	10	16	25	40	62	--	--	--	--	--	--	--
92-100 Series	8.3	6.7	5.7	10	16	25	40	62	--	--	--	--	--	--	--
93-100 Series	8.3	6.7	5.7	10	16	25	40	62	--	--	--	--	--	--	--
94A-100/200 Series	6	7	19	34	50	104	268	309	629	1018	1622	--	--	--	--
96-100 Series	8.3	6.7	5.7	10	16	25	40	62	--	--	--	--	--	--	--
399-100 Series	8.4	7.2	15	30	43	48	84	108	190	370	--	--	--	--	--
489-100 Series	8.4	7.2	15	30	43	48	84	108	190	370	--	--	--	--	--

PRESSURE TEMPERATURE RATINGS

Class 300

(CS) ASTM A216-WCB

(GRAPH 5)

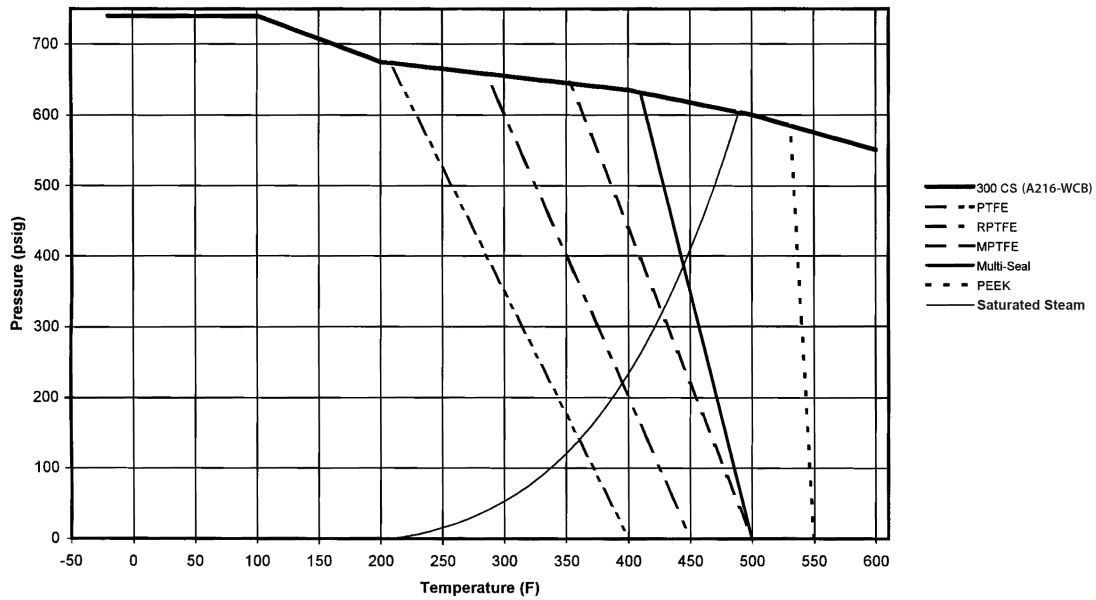

Class 300

(SS) ASTM A351-CF8M

(GRAPH 6)

